

Description

Foot valves is a check valve for suction purposes, equipped with a strainer and mounted in the end of a pipe

Specifications

Flange standard:	EN 1092-2
Bonnet connection:	Bolted
Execution:	Straight
Connection type:	Flanged
Perforation:	5 x 5 mm



Media

Fuel oil, lubricating oil and flammable hydraulic oil. Cargo oil. Seawater and freshwater.

Variants

Other materials on request.

Material

No.	Part	Material
1	Body	Cast iron EN-JL1040 (GG25)
2	Disc	Cast iron EN-JL1040 (GG25)
3	Disc ring	EPDM
4	Bonnet	Cast iron EN-JL1040 (GG25)
5	Basket	Galvanized steel

Max. working pressure (bar) at °C

DN	Connection	90°C
40 - 150	PN 16	10
200 - 300	PN 10	6

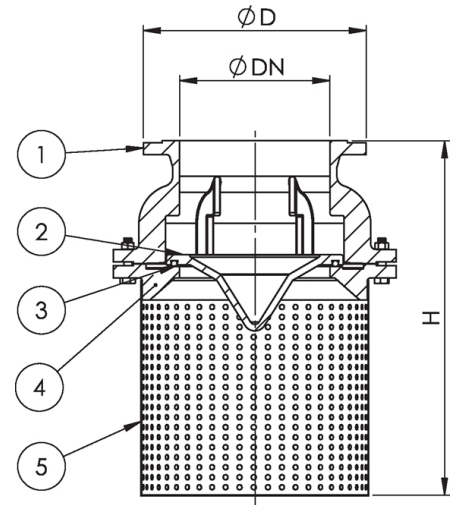

Items

DN	Item no.	Pressure rating	Connection	D	H	Kv	Weight (kg)	Color
40	80909	PN 10	PN 16	150	175	27	7.0	Green RAL 6002
50	40075	PN 10	PN 16	165	195	43	8.0	Green RAL 6002
65	40076	PN 10	PN 16	185	230	72	10.0	Green RAL 6002
80	81553	PN 10	PN 16	200	255	101	14.0	Green RAL 6002
100	81685	PN 10	PN 16	220	290	181	21.0	Green RAL 6002
125	81142	PN 10	PN 16	250	340	294	26.0	Green RAL 6002
150	80905	PN 10	PN 16	285	390	414	44.0	Green RAL 6002
200	81143	PN 6	PN 10	340	530	756	72.0	Green RAL 6002
250	40077	PN 6	PN 10	395	620	1162	100.0	Green RAL 6002
300	40078	PN 6	PN 10	445	700	1761	160.0	Green RAL 6002

All measurements in mm. Weights and Kv-values are approximations.