



Butterfly Valve

Fully Lugged Wafer Type



sylax
PN16

Description: Fully lugged wafer type, ductile iron body, replaceable rubber liner, suitable for fitting between PN16 flanges

Application: Isolating of flow of water, WRAS & KIWA approved for potable water

Standard & Design:

Connection Standard: EN1092-1 And EN1092-2
 Face To Face Standard: EN 558, Series 20
 Execution: Wafer
 Connection Type: For Mounting Between Flanges

Options: Lever, Gear, Actuators
 Larger sizes upon request



Max. Working Pressure (bar) at °C:

DN	85°C	120°C
50 - 350	16	2.5

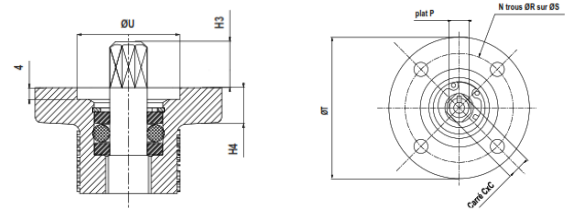

Material:

No	Part	Material	Code
1	Body	Ductile Iron	JS 1030
2	Liner	EPDM	-
3	Disc	Stainless Steel	1.4408
4	Stem	Stainless Steel	1.4404
5	Anti-Friction Bearing	Zinc Coated Steel + PTFE	-
6	Anti-Friction Bearing	Plastic	-
7	Sealing Bush	Nitrile/FKM	-
8	O-Ring seal	Stainless Steel	1.4028
9	Circlips	Steel	XC 75
10	ID Plate	Aluminium	AL995
11	Rivet	Alu / St/Steel	-

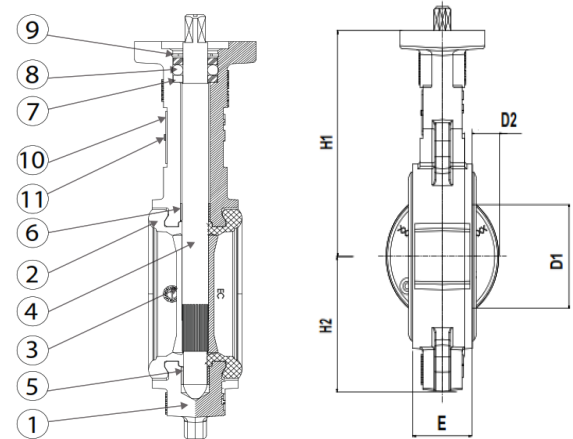

DN	E	H1	H2	H4	N	ØR	ØS	ØT	ØØ	N°	□C	H3	P	Kg
50	43	136	62	12	4	6.5	50	65	36	F05	11	16	11	3.0
65	46	145	70	12	4	6.5	50	65	36	F05	11	16	11	3.3
80	46	151	89	12	4	6.5	50	65	36	F05	11	16	11	4.2
100	52	175	103	10	4	6.5	50	65	36	F05	11	16	11	6.0
125	56	190	119	12	4	8.5	70	90	56	F07	14	19	14	6.2
150	56	203	133	12	4	8.5	70	90	56	F07	14	19	14	7.1
200	60	225	163	12	4	8.5	70	90	56	F07	14	19	14	15.7
250	68	266	198	14	4	10.5	102	125	71	F10	17	24	20	23.0
300	77	290	227	14	4	10.5	102	125	71	F10	22	29	16	34.0
350	77	305	224	16	4	10.5	125	150	87	F12	27	29	-	46.0

All measurements in mm. Weights are approximations