



# Installation and maintenance manual

## Quick Closing Valve

LK product no: 901002 and 901102

Manufacturer LK Valves AB, Sweden



(Intentionally left blank)

## Contents

<b>1. General information</b>	<b>5</b>
<b>2. Safety precautions</b>	<b>5</b>
2.1. Significance of symbols	5
2.2. Explanatory notes on safety information	5
<b>3. Storage and transport</b>	<b>7</b>
<b>4. Description</b>	<b>7</b>
4.1. Scope of applications	7
4.2. Operating principles	8
4.3. Technical data	12
<b>5. Installation</b>	<b>16</b>
5.1. General notes for installation	16
5.2. Installing the quick closing valve	17
5.3. Installing the mechanical release system	19
5.4. Putting the valve into operation	19
<b>6. Maintenance instruction</b>	<b>21</b>
<b>7. Repair</b>	<b>21</b>
7.1. Dismantling of the quick closing valve	21
7.2. Putting quick closing valve into operation after repair	22
7.3. Repair kit Quick Closing Valve	22
7.4. Repair of Release Cylinders (I I)	23
<b>8. Contacts</b>	<b>23</b>

(Intentionally left blank)

## **1. General information**

This manual gives instructions on installation of the Quick Closing Valves together with maintenance instructions and shall be read carefully before installation is started.

It is in the responsibility of the installer to ensure that the work is carried out in a satisfactory manner, approved materials are used and that the installation meets applicable rules and regulations.

Regional safety requirements must be applied and observed both at installation and maintenance as well as in repair work

It is the installer/owners responsibility to define responsibility and competence of personnel for the installation and maintenance of the valves.

In case of problems which cannot be solved from information in this manual the supplier of the valves shall be contacted.

The notes and warnings defined in following chapters must be followed as this information concerns your safety.

Note! Part numbering (..) in chapter 4.3.2 Part list are maintained and used as references through all chapters.

The manufacturer reserves the right to introduce technical modifications at any time.

## **2. Safety precautions**

### **2.1. Significance of symbols**



**ATTENTION!**

Warning of general danger.

### **2.2. Explanatory notes on safety information**

In these Operating and Installation Instructions dangers, risks and items of safety information is highlighted to attract special attention.

Information marked with the above symbol and "**ATTENTION!**" describes practices, a failure to comply with which can result in serious injury or danger of death for users or third parties or in material damage to the system or the environment. It is vital to comply with these practices and to monitor compliance.

All other information not specifically emphasised such as transport, installation, operating and maintenance instructions as well as technical data (in the operating instructions, product documentation and on the device itself) must also be complied with to the fullest extent in order to avoid faults which in turn can cause serious injury to persons or damage to property.

(Intentionally left blank)

### 3. Storage and transport



#### **ATTENTION!**

Protect valve and other equipment against external forces.

Valve hand wheels (10) and release cylinders (11) are not designed to take external forces e.g. they must not be used for as climbing aids or as connection of lifting gear.

Lifting to be carried out by using suitable handling equipment.

Weights of valves to be taken from data sheet.

- The valves are delivered with plastic protection covers in both flange ends and in the pipe connection to the release cylinder (11). The covers shall not be removed until the installation.
- If the covers have been removed inspect the internals carefully for dirt before installation.
- The valves must be stored indoors well protected from dust and moisture.
- Long time storing must be done in warm warehouses to avoid corrosion attack on unprotected areas inside the valve.
- Do not damage the external coating during transportation and storing.

### 4. Description

#### 4.1. *Scope of applications*

The valve is used for shut-off of media from a remote place and to close locally by hand.



#### **ATTENTION!**

- The applications and limitations given in these documents must be followed.
- Installation in heavy vibrating pipe lines is not recommended.

- The valves have been Type Approved by all major Classification Societies.
- The markings of the valves must be taken into account for each application.
- It is in the responsibility of the installer to ensure compliance with the actual Type Approval and eventually other local rules.
- Please contact the supplier or the manufacturer if you have any questions regarding the application.

## 4.2. Operating principles

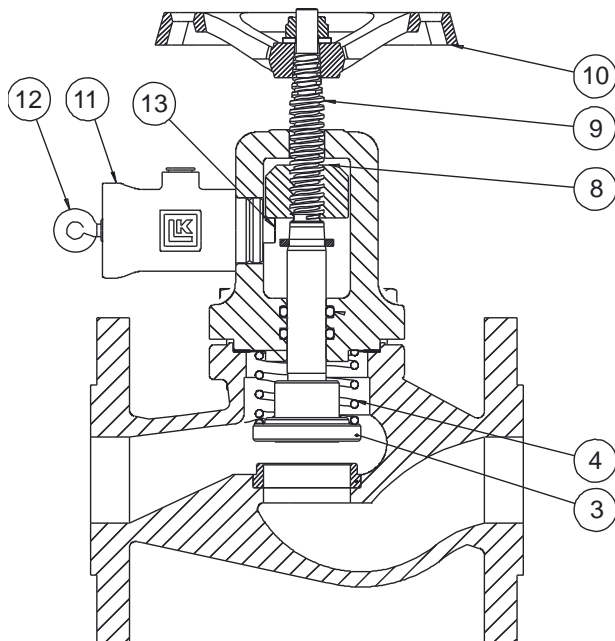

The valve is a stop valve with a remote quick closing function, but can also serve as a conventional stop valve by using the hand wheel (10).

- ❑ The quick closing action is instantly carried out by a spring (4), pre-compressed by turning the hand wheel (10).
- ❑ The stem (9) and attached disc (3) is hooked up by means of the setting nut (8).
- ❑ When the setting nut is released from loaded position - the valve will close.

Release from loaded position is done by the release mechanism, see following description of release alternatives.

Retracting the piston rod (13) extension in the release cylinder (11) by hand will also close the valve.



#### 4.2.1. Loading the valve for Quick Closing

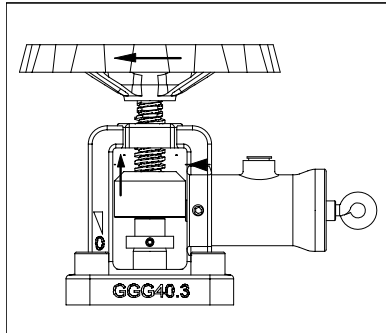

- ❑ Turn the hand wheel (10) in closing direction (clockwise) until the piston rod (13) in the cylinder comes out and holds the setting (8) nut in its upper position.

**Note!** The ring on the stem (9) indicates that the valve is closed when the ring is in the same height as the zero in the indicating symbol at the side of the bonnet (7).

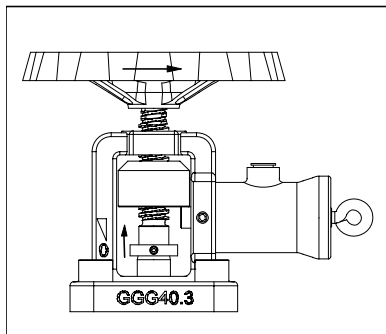

- ❑ Turn the hand wheel (10) in opening direction (anti clockwise).

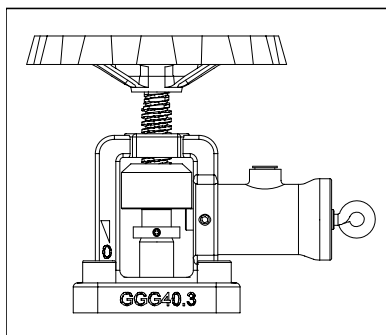

- ❑ Stop the turning of the hand wheel (10) when the mechanical stop is felt and the setting nut (8) is in hard contact with the shoulder on the stem (9).



### **ATTENTION!**

It is important that the spring force inside the release cylinder (11) is pushing out the piston rod (13) fully.

**4.2.2. Closing of valve by the remote Quick Closing function**

The valve is quick closed by a remote hydraulic or pneumatic signal or by pulling back the piston rod (13) of the universal release cylinder (11) by a wire arrangement. In all systems also the fire release arrangement is operating by the melting ring which in case of contact with fire will close the valve.



- Be aware of the fact that the valve stem with related components as hand wheel (10) will fall down very rapidly by spring force at closing of the valve which can cause injury.
- Also avoid injury by always secure the release system when work is carried out on the valve. When testing the remote release system, stay away from moving parts on the valve.

**4.2.3. Closing of valve by the remote Mechanic system**

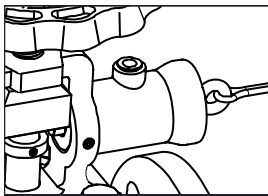

The mechanical release system is arranged by connecting a wire to the eye bolt (12). By pulling the wire the piston rod (13) is moved to release position and the valve will close.

**4.2.4. Closing of valve by the Automatic fire release**

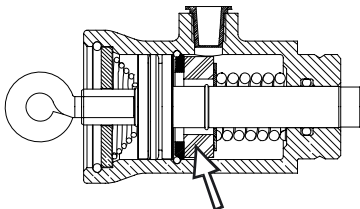

The release cylinder is internally equipped with a melting ring (see arrow) which will melt at temperatures above 178 °C. The strong spring will push the piston rod (13) into the release cylinder (11) allowing the valve to close by spring force.



- It is important that the release cylinder (11) is replaced when it has been exposed to excessive heat.

#### 4.2.5. Closing valve by hand wheel (10)

The valve can be closed by the hand wheel (10), when required.

Turn the hand wheel (10) in clockwise direction. The setting nut (8) will then be fully pushed up against the top of the bonnet (7), which holds the disc (3) in shut off position.

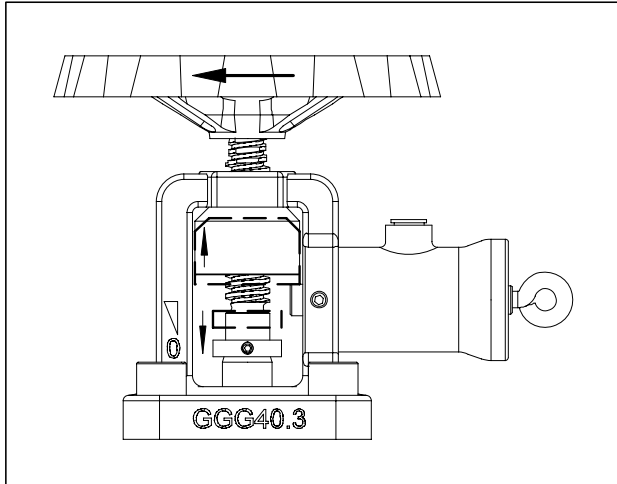

**ATTENTION!**

Do not use tools to increase the torque on the hand wheel (10).

### 4.3. Technical data

#### 4.3.1. Dimensions

Dimensions (mm)

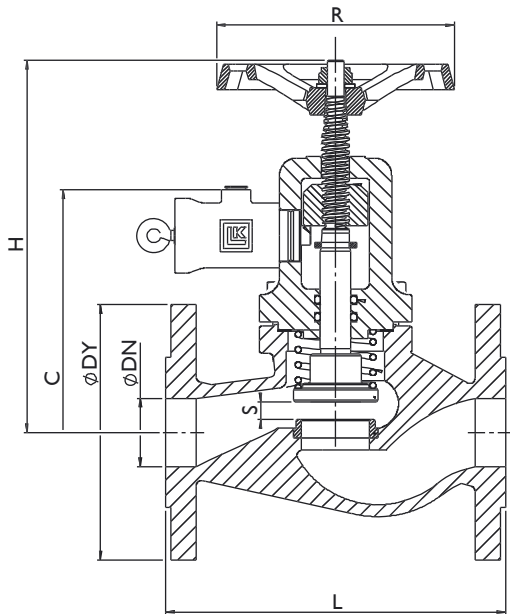

SIZE	PN	ØDY	L	H <sub>open</sub>	H <sub>closed</sub>	R	S	C	Kg
DN15	16	95	130	180	172	120	7,5	119	4,5
DN20	16	105	150	180	172	120	7,5	119	5,0
DN25	16	115	160	198	190	120	8,0	136	5,9
DN32	16	140	180	198	190	120	8,0	136	7,4
DN40	16	150	200	210	200	140	10,0	139	10,1
DN50	16	165	230	220	207	140	12,5	148	12,5
DN65	16	185	290	258	241	140	16,5	166	17,4
DN80	16	200	310	277	257	160	20,0	183	23,0
DN100	16	220	350	304	279	160	25,0	198	32,0
DN125	16	250	400	350	318	200	32,0	231	50,8
DN150	16	285	480	410	372	200	37,5	291	72,3
DN200	10	340	600	553	503	400	50,0	376	150,0
DN250	10	405	730	585	523	400	63,0	404	230,0

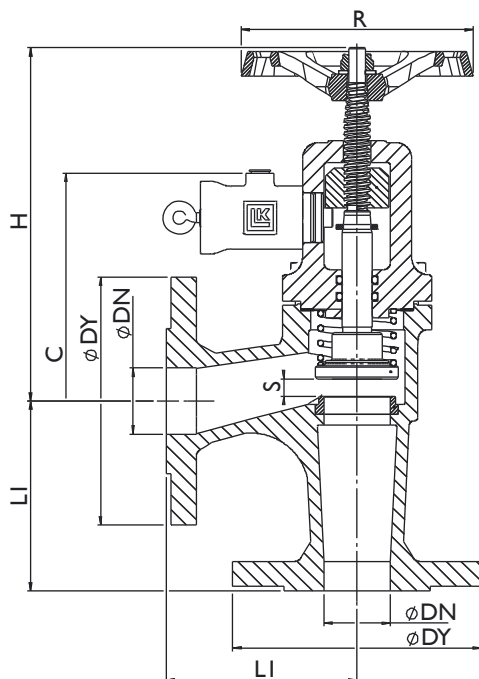

SIZE	PN	ØDY	L1	H <sub>open</sub>	H <sub>closed</sub>	R	S	C	Kg
DN15	16	95	90	175	168	120	7,5	114	4,6
DN20	16	105	95	172	165	120	7,5	111	5,3
DN25	16	115	100	185	177	120	8,0	124	6,1
DN32	16	140	105	189	181	120	8,0	128	7,7
DN40	16	150	115	209	199	140	10,0	138	10,5
DN50	16	165	125	205	193	140	12,5	133	12,7
DN65	16	185	145	238	222	140	16,5	147	17,0
DN80	16	200	155	250	230	160	20,0	156	22,4
DN100	16	220	175	278	253	160	25,0	172	33,5
DN125	16	250	200	296	264	200	32,0	177	48,0
DN150	16	285	225	344	307	200	37,5	226	65,3
DN200	10	340	275	458	408	400	50,0	281	150,0
DN250	10	405	325	463	400	400	63,0	282	230,0

**4.3.2. Part list**

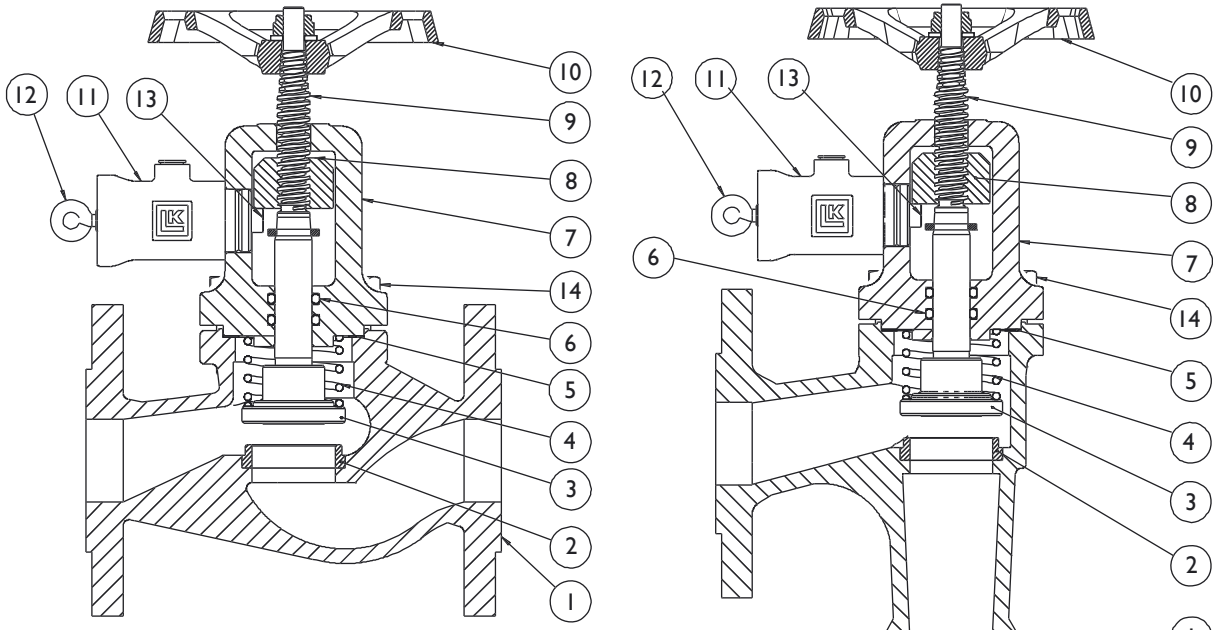

DN15-150

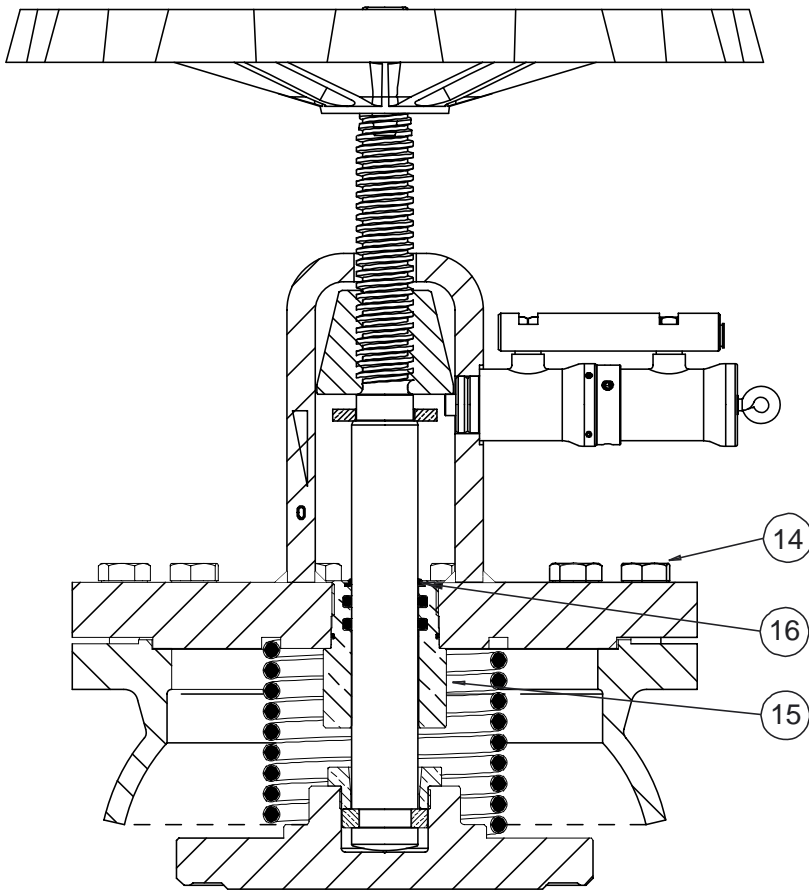

DN200-250

Pos.	Item
1	Valve body
2	Seat ring
3	Disc
4	Spring
5	Gasket
6	O-ring
7	Bonnet
8	Setting nut
9	Stem
10	Hand wheel
11	Release cylinder
12	Eye bolt
13	Piston rod
14	Screw
15	O-ring housing
16	Scraper

**4.3.3. Release cylinder (11)**

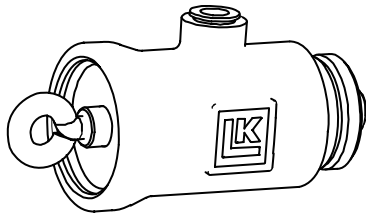

DN15-100

Technical data for the release cylinder (11)	
Stroke volume	3,5 cm <sup>3</sup>
Recommended minimum working pressure from system	6 bar
Max hydraulic static pressure	0,7 bar *)
Pressure class	PN30
Fire release temperature	178°C
Connecting thread	ISO G1/8"

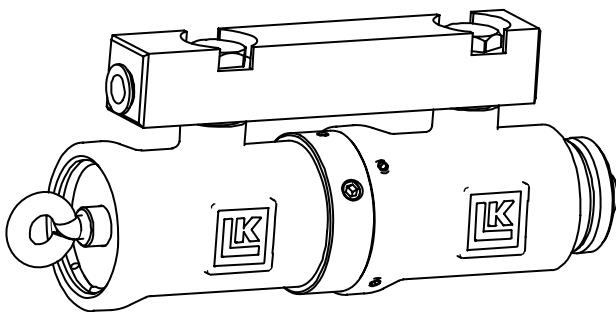

DN125-250

Technical data for the twin release cylinder (11)	
Stroke volume	7,0 cm <sup>3</sup>
Recommended minimum working pressure from system	6 bar
Max hydraulic static pressure	0,7 bar *)
Pressure class	PN30
Fire release temperature	178°C
Connecting thread	ISO G1/8"

\*) Static pressure in hydraulic systems over 0.7 bar requires a Support Kit. The kit compensates a static pressure up to 4.0 bar.

*Support Kit*

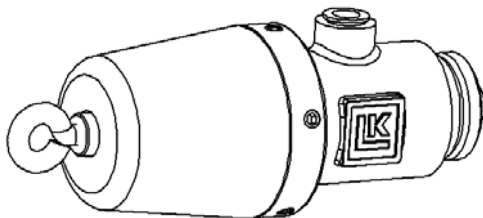

Support Kit  
DN15-100

Technical data for the release cylinder ( single & twin) with Support Kit (11)	
Article No. Support Kit	75758
Stroke volume	3,5 cm <sup>3</sup>
Max hydraulic static pressure	4,0 bar
Pressure class	PN30
Fire release temperature	178°C
Connecting thread	ISO G1/8"

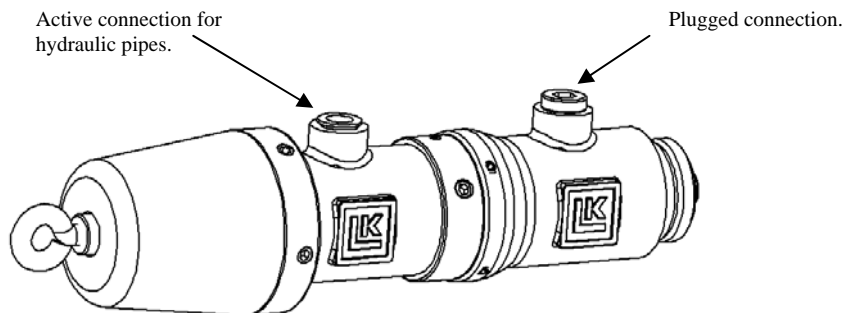

Support Kit  
DN125-250

### 4.3.4. Marking

The quick closing valve is identified by reading the individual manufacturing number engraved on the valve bonnet (7).

The valve castings can be traced by size and the casting identification on the valve body (1).

All Quick Closing Valves have the following markings:

- Serial number engraved on the valve bonnet (7).
- Size, pressure class and material on valve body (1).
- Flow direction on valve body (1).
- LK Valves web site on bonnet (7).
- Manufacturers logo on valve body (1)
- Manufacturers casting identification

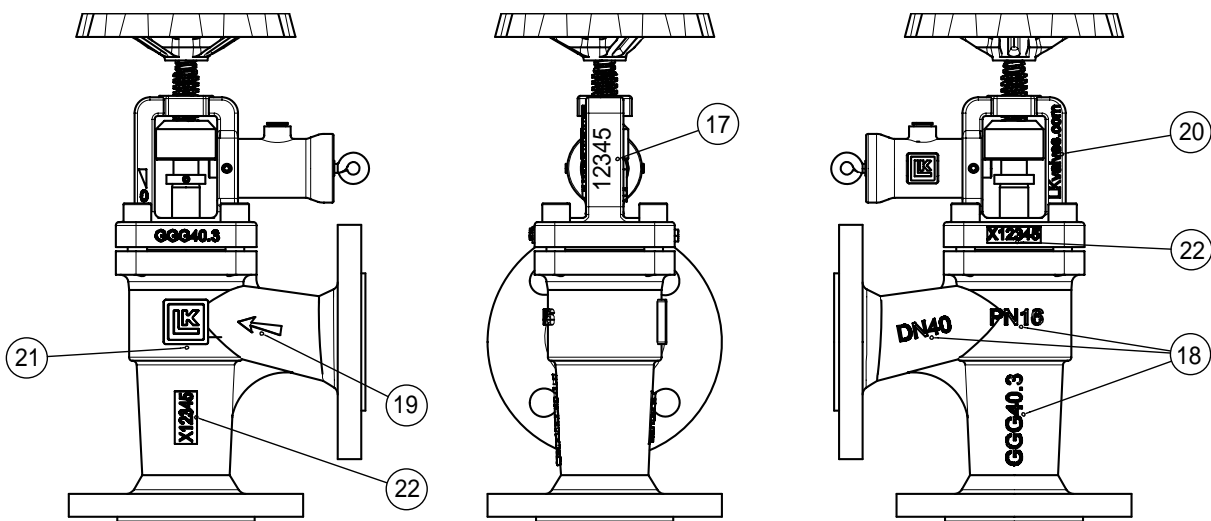

## 5. Installation

### 5.1. General notes for installation

- Installation/construction companies or operators are responsible for positioning and installing the valves and related operating systems.
- Following points shall be taken into account at installation work.



#### **ATTENTION!**

- Remove protecting covers for valve flanges.
- Protect valve from dirt during the whole installation procedure.
- Check for dirt and foreign particles in valves and pipelines.
- Note installation positions with reference to flow and marking arrow (19) on valve.
- Use only counter flanges and screws with correct dimensions.
- Centre gaskets between flanges.
- Avoid damaging forces on valve when pipeline is installed.
- Valve hand wheels and actuators are not designed to take external forces e.g. they must not be used for as climbing aids or as connection of lifting gear.
- Lifting to be carried out by using suitable handling equipment.
- Weights of equipment to be taken from data sheet.
- Installation of the valve with stem vertical is preferred, but all positions indicated below can be used.

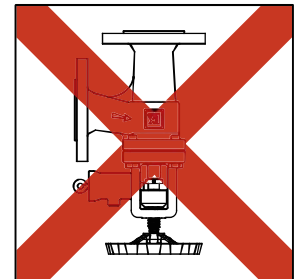
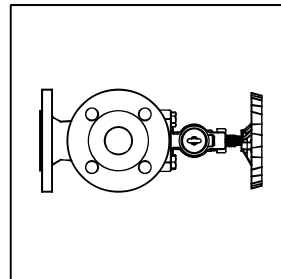
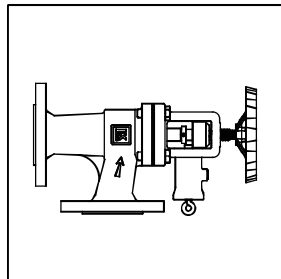
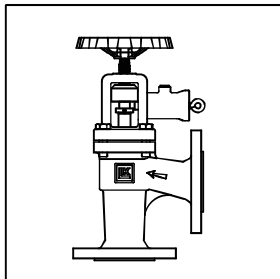
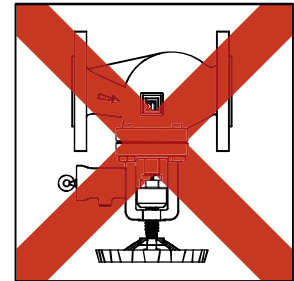
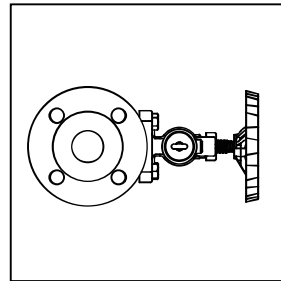
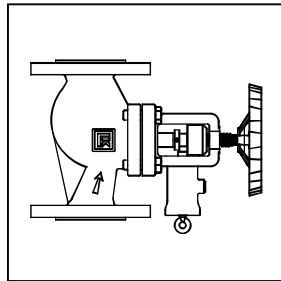
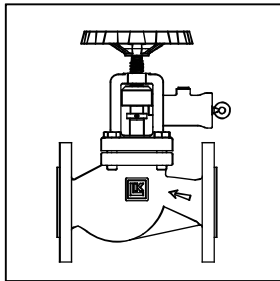

- Keep stem threads and shaft free from paint
- Protect the piston rod in the release cylinder from dirt and paint under the whole installation procedure.
- Do not remove the protecting cap in the threads to the release cylinder until the pipe will be connected.



## 5.2. Installing the quick closing valve

### 5.2.1. Change direction of valve bonnet (7)

- The direction of the valve bonnet (7) can be turned to suit the installation.
- With the valve in open position remove the screws (14) holding the bonnet (7).
- Turn the bonnet (7) without damage the gasket (5) between valve body (1) and bonnet (7).
- Fit the screws (14) and tighten again.
- Check the gasket for leakage and that the release mechanism is functioning.

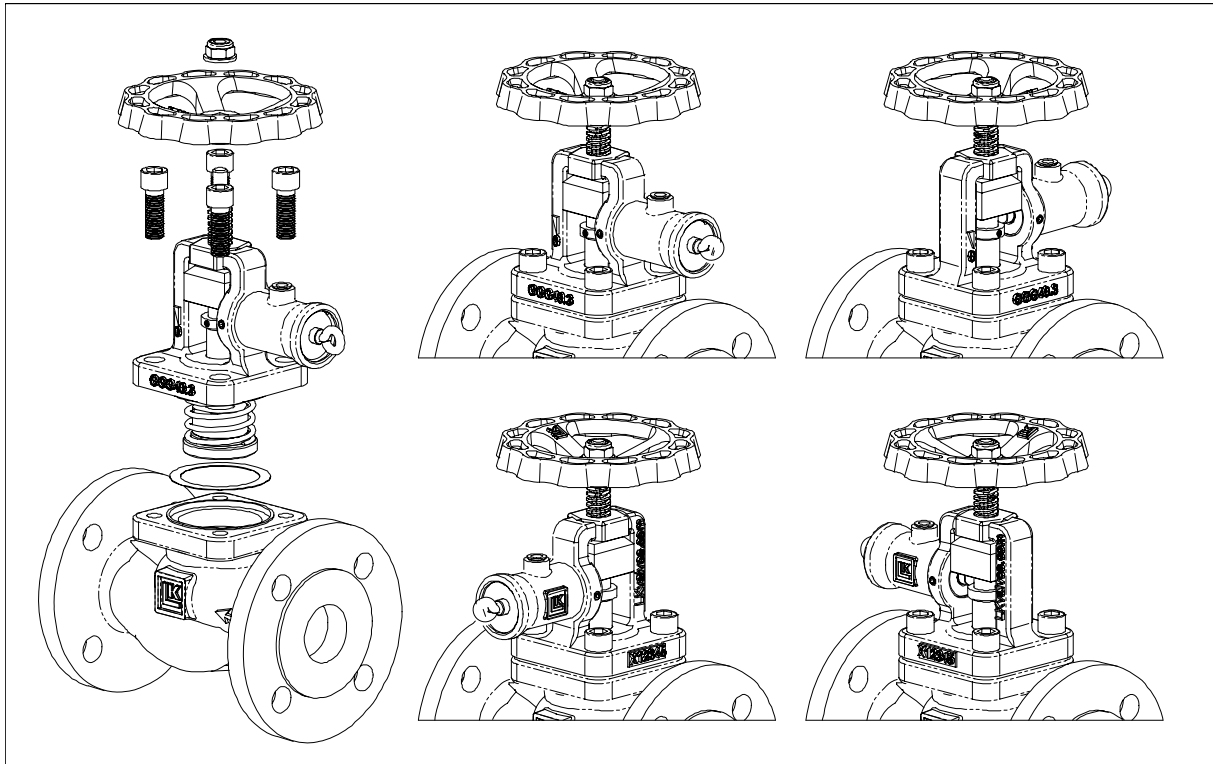

### 5.2.2. Change direction of release cylinder (11) connecting threads

- The release cylinder (11) can be turned to suit direction of the release pipe.
- Loosen the two socket screws and turn the release cylinder (11) in position to suit the direction of the pipe line.
- Be sure that the cylinder (11) is positioned correct in the bonnet (7) and tighten the socket screws.
- To facilitate the air venting of the release cylinder (11) in a hydraulic remote system the cylinder (11) should be kept in delivered position with thread connection at top.

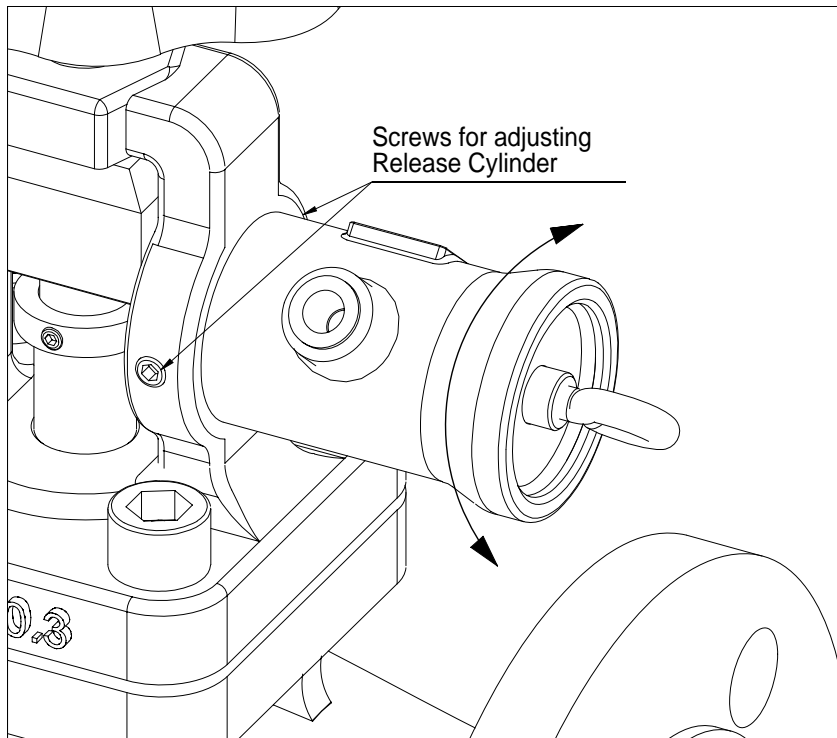

#### **ATTENTION!**

- The valve is not designed for installation in heavy vibrating pipe lines (close to main engines and generator engines). If this must be the case all precautions must be taken to prevent the valve from these vibrations.

### 5.3. Installing the mechanical release system

Connect the wire to the eye bolt (12) in the end of the release cylinder (11).

Note! To avoid an accidental release by ship movements in heavy sea, make sure that there is no tension in the wire.

The return spring inside the cylinder (11) is keeping the piston rod (13) in position. With the setting nut (8) in top position (no force acting on the piston rod (13)) check that the wire arrangement not is moving the piston to release position.



#### **ATTENTION!**

- It is important that the weight of the wire is unloaded all the way down to the release cylinder (11) and that the return spring can hold the piston rod (13) in position.

### 5.4. Putting the valve into operation



#### **ATTENTION!**

- Before the valve is put into operation check that it is the right valve in its right position (material, pressure, temperature and direction of flow).
- Residues in piping and valves (dirt, weld beads, etc.) inevitable lead to leakage.
- Check remote control system function and operation directly on valve.
- Be aware of the fact that the valve stem (9) with related components as hand wheel (10) will fall down very rapidly by spring force at closing of the valve which can cause injury.
- Also avoid injury by always securing the release system when work is carried out on the valve. When testing the remote release system, stay away from moving parts on the valve.
- Regional safety instruction must be adhered to.
- Touching valves operating at high media temperatures  $>50^{\circ}\text{C}$  can cause injury.
- Affix warning notice or protective insulation as appropriate.
- Before putting a new plant into operation or restarting after repairs or modifications, always make sure that:
  - All works has been completed for the valves and other depending systems.
  - Valve is loaded for remote operation.

(Intentionally left blank)

## 6. Maintenance instruction

The valve is maintenance free but we recommend following to be checked at regular intervals

- When valves can be closed without disturbing the proper function of the piping system use the remote control system and close the valves.
- Also check operation directly on the valve.
- Clean the area around the stem (9) from dirt coming in contact with the stem and check for leakage between bonnet (7) and stem (9) or damage on stem surface.

- Check that the piston rod (13) in release cylinder (11) is kept in outer position.

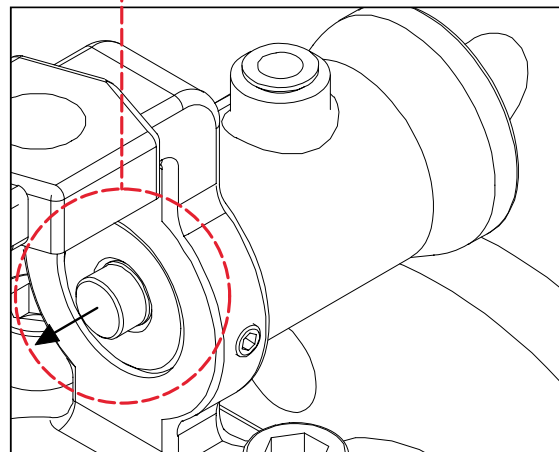
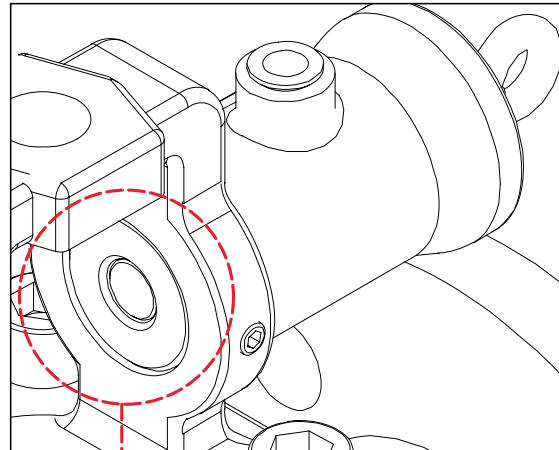

## 7. Repair

### 7.1. Dismantling of the quick closing valve



#### **ATTENTION!**

The following points must be observed before dismantling the valve:

- Pressure less pipe system.
- Medium and valve must cool.
- Plant must be drained.
- Cleansing of the piping system in case of dangerous media.

### 7.2. Putting quick closing valve into operation after repair



#### **ATTENTION!**

- Before the valve is put into operation check that it is the right valve in its right position (material, pressure, temperature and direction of flow).
- Residues in piping and valves (dirt, weld beads, etc.) inevitable lead to leakage.
- Check remote control system function and operation directly on valve.
- Be aware of the fact that the valve stem with related components as hand wheel (10) will fall down very rapidly by spring force at closing of the valve which can cause injury.
- Also avoid injury by always secure the release system when work is carried out on the valve. When testing the remote release system, stay away from moving parts on the valve.
- Regional safety instruction must be adhered to.
- Touching valves operating at high media temperatures >50°C can cause injury.
- Affix warning notice or protective insulation as appropriate.

Before putting a new plant into operation or restarting after repairs or modifications, always make sure that:

- All works has been completed for the valves and other depending systems.
- Valve is loaded for remote operation.

### 7.3. Repair kit Quick Closing Valve

The repair and service kit contains o-rings (pos. 6) and gasket (pos. 5).

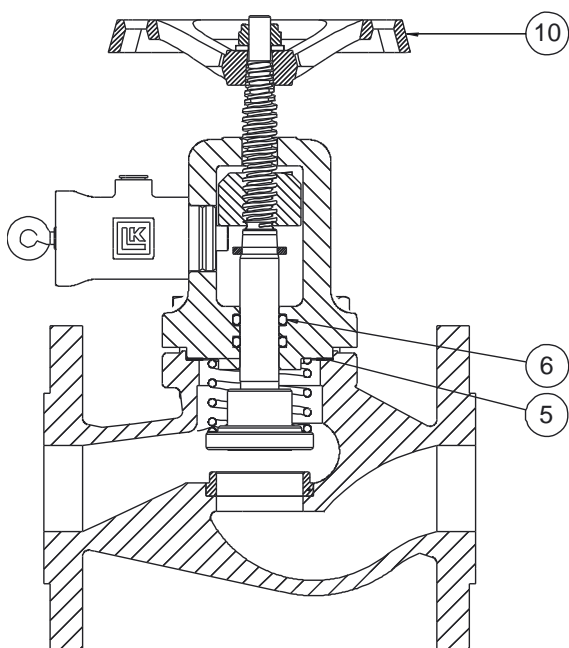

SIZE	Repair kit: LK art. no. Contains two pcs o-rings (6) & one gasket (5)	Hand wheel (10) LK art. no.
DN15	75643	80487
DN20	75643	80487
DN25	75644	80487
DN32	75644	80487
DN40	75645	80488
DN50	75646	80488
DN65	75647	80488
DN80	75648	80489
DN100	75649	80489
DN125	75650	81033
DN150	75651	81033
DN200	75652	82082
DN250	75653	82082

### 7.4. Repair of Release Cylinders (11)

Only completely assembled release cylinders (11) can be supplied.



**ATTENTION!**

- It is important that the release cylinder (11) is replaced when it has been exposed to excessive heat.
- Never dismantle the release cylinder (11). It contains strong springs that can cause injury if they are dismantled.

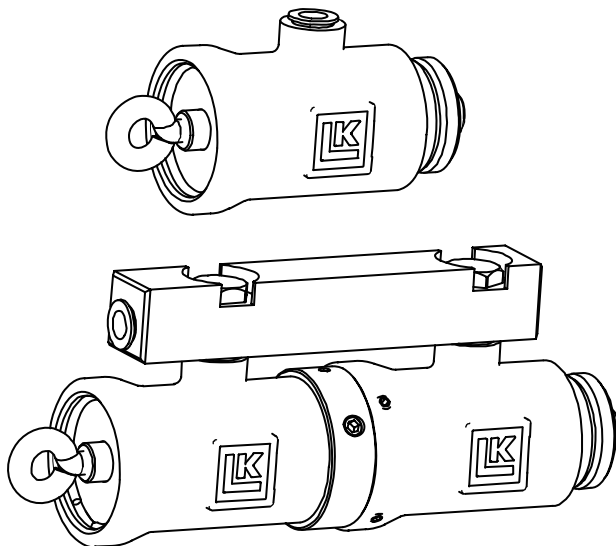

Valve size	Spare Release Cylinder LK article number
DN15-100	75000
DN125-250	75518

## 8. Contacts

Your Quick Closing Valves are designed and manufactured by:

LK Valves AB  
Garnisonsgatan 19  
SE-254 66 Helsingborg  
SWEDEN

Telephone: +46 (0)42 38 38 70  
Fax: +46 (0)42 38 38 75

Website: <http://www.lkvalves.com>  
E-mail: [helsingborg@lkvalves.com](mailto:helsingborg@lkvalves.com)