

Description Sight glass with double tempered inspection glass.

Specifications

Flange standard:	EN 1092-2
Bonnet connection:	Bolted
Execution:	Straight
Connection type:	Flanged



Media

Fuel oil, lubricating oil and flammable hydraulic oil. Cargo oil. Non-flammable hydraulic fluid. Boiler feedwater, condensate. Seawater and freshwater.

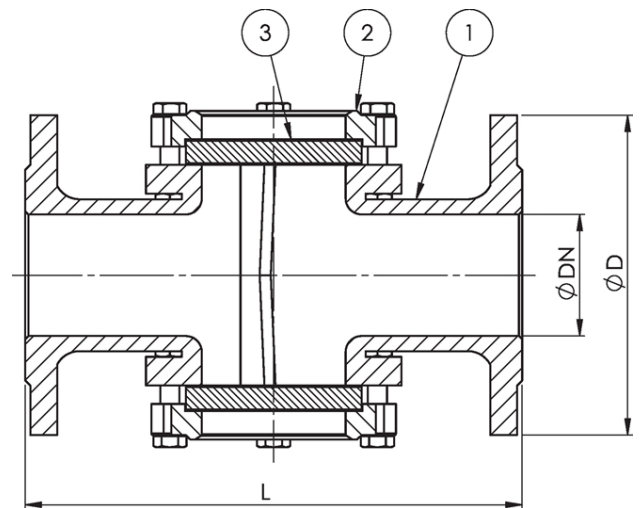

Material

No	Part	Material
1	Body	Cast iron EN JL1040 (GG 25)
2	Bonnet	Cast iron EN-JL1040 (GG 25)
3	Glass	Double tempered glass

Max. working pressure (bar) at °C

DN	Connection	up to 120°C	150°C	180°C	200°C	230°C	250°C	320°C
15 - 250	PN 16	16	14.4	13.4	12.8	11.8	11.2	9.6

Sight glass

DN	Item no.	Pressure rating	Connection	L	D	Weight (kg)
15	40421	PN 16	PN 16	135	95	3.0
20	92613	PN 16	PN 16	150	105	4.0
25	89997	PN 16	PN 16	160	115	4.0
32	82027	PN 16	PN 16	180	140	6.0
40	81960	PN 16	PN 16	200	150	7.0
50	81961	PN 16	PN 16	230	165	9.0
65	81962	PN 16	PN 16	290	185	17.0
80	81963	PN 16	PN 16	310	200	18.0
100	90600	PN 16	PN 16	350	220	23.0
125	91461	PN 16	PN 16	400	250	50.0
150	91801	PN 16	PN 16	480	285	63.0
200	81984	PN 16	PN 16	600	340	120.0
200	80530	PN 16	PN 10	600	340	120.0
250	40422	PN 16	PN 16	730	405	160.0
250	80531	PN 16	PN 10	730	405	160.0

All measurements in mm. Weights are approximations.

