



Check Valve

Swing Type, Flanged Ends

F-7373
JIS 10K

Description: Swing type check valve, cast iron body, metal seated, bolted bonnet, flat faced flanged

Application: Prevent backflow of; sea water, water, and oils, etc

Standard & Design:

Design Code:	JIS F7373
Inspection Standard:	JIS F7400
Flange Standard:	JIS B2239
Face To Face Standard:	JIS F7425 (F7373)
Flanges Drilled:	JIS 10K (DN50-DN200)
Pressure Rating:	JIS 10K (DN50-DN200)



Material:

No	Part	Material	Code
1	Body	Cast Iron	HT200
2	Sealing Ring	Stainless Steel	2Cr13
3	Disc	Stainless Steel	2Cr13
4	Rocker	Stainless Steel	2Cr13
5	Gasket	Graphite	-
6	Cover	Cast Iron	HT200
7	Nut	Carbon Steel	Q235A
8	Double Open Ended Bolt	Carbon Steel	Q235A

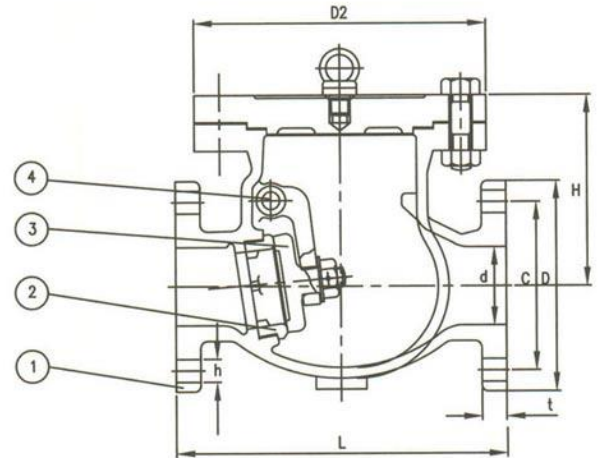

DN	n x Øh	C	D	L	H (max)
50	4x19	120	155	210	109
65	4x19	140	175	240	126
80	8x19	150	185	270	135
100	8x19	175	210	300	153
125	8x23	210	250	350	180
150	8x23	240	280	400	205
200	12x23	290	330	480	242

All measurements in mm. Weights are approximations