



# Globe Valve

## Straight Type, Flanged Ends

F-7313/F-7473  
JIS 20K

**Description:** Straight type, cast steel body, metal seated screw down stop valve with rising stem, bolted bonnet, flat faced flanged

**Application:** Start/stop and throttling of; sea water, water, steam and oils, etc

**Standard & Design:**

Design Code: JIS F7313  
 Inspection Standard: JIS F7400  
 Flange Standard: JIS B2220  
 Face To Face Standard: JIS F7426 (F7313)  
 Flanges Drilled: JIS 20K (DN32-DN250)  
 Pressure Rating: JIS 20K (DN32-DN250)

**Variations:**

F-7313=Fixed Disc  
 F-7473=SDNR



**Material:**

No	Part	Material	Code
1	Body	Cast Steel	ZG230-450
2	Bonnet	Cast Steel	ZG230-450
3	Gland	Stainless Steel	2Cr13
4	Disc	Stainless Steel	2Cr13
5	Stem	Stainless Steel	2Cr13
6	Gasket	Graphite	-
7	Split Pin	Carbon Steel	A3
8	Nut	Carbon Steel	Q235A
9	Gasket Ring	Carbon Steel	Q235A
10	Screw	Carbon Steel	Q235A
11	Screwed Bonnet Bush	Brass	H62
12	Double Open End Bolt	Carbon Steel	Q235A
13	Packing	Graphite	-
14	Double Open End Bolt	Carbon Steel	Q235A
15	Packing Seat	Brass	H62
16	Check Washer	Brass	H62
17	Disc Nut	Stainless Steel	2Cr13
18	Sealing Nut	Stainless Steel	2Cr13
19	Handwheel	Cast Iron	HT200

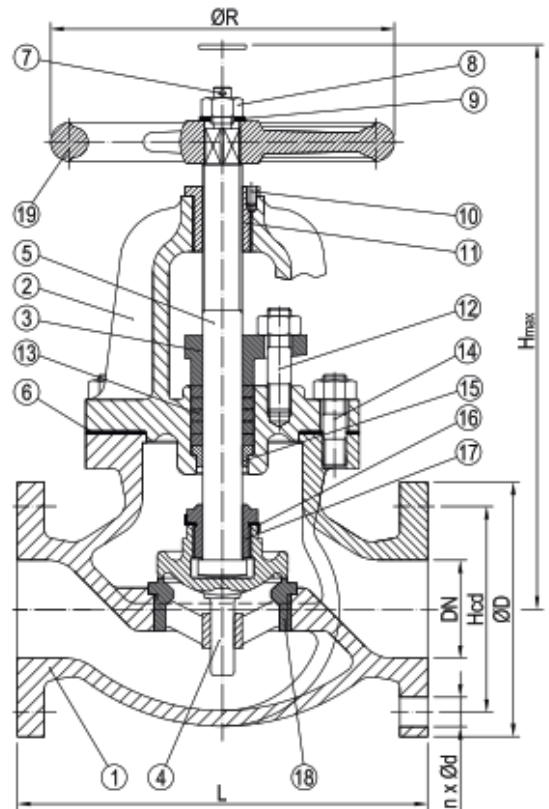

DN	n x Ød	Hcd	ØD	L	H (max)	ØR	Kg
32	4x19	100	135	190	270	160	14.4
40	4x19	105	140	200	290	160	16.0
50	8x19	120	155	230	305	200	21.6
65	8x19	140	175	270	345	225	30.4
80	8x23	160	200	300	385	250	43.5
100	8x23	185	225	350	440	280	62.3
125	8x25	225	270	430	500	315	95.7
150	12x25	260	305	500	550	355	133.3
200	12x25	305	350	560	630	450	296.0
250	12x27	380	430	660	725	560	339.0

All measurements in mm. Weights are approximations