



# Foot valve 321001

## DESCRIPTION

Mesh-size:

- DN 15-300: 5x5
- DN 350-500: 8x8

## APPLICATION

Liquids that do not attack the integral material.

## VARIANTS

Other strainer materials and mesh-sizes upon request.



No.	Part	Material
1	Body	Nodular cast iron EN-JS1025 (GGG40.3)
2	Disc	Nodular cast iron EN-JS1025 (GGG40.3)
3	Disc ring	EPDM
4	Bonnet	Nodular cast iron EN-JS1025 (GGG40.3)
5	Basket	Galvanized steel

DN	Max. working pressure (bar)	
	90°C	
15-150	10	
200-300	6	
350-500	4	

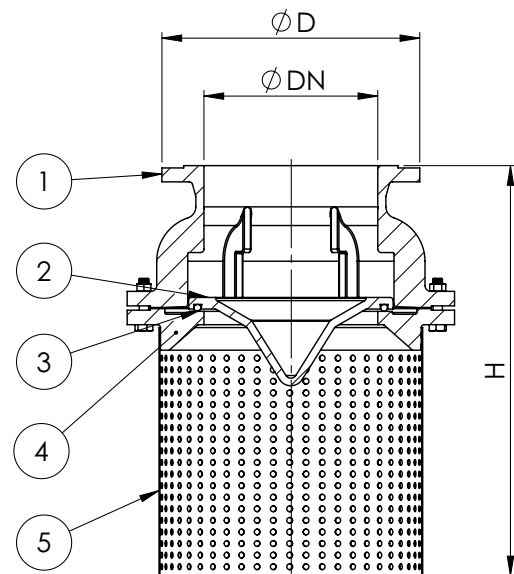

DN	Connection	Pressure rating	D	H	Kg
40	PN 16	PN 10	150	230	7
50	PN 16	PN 10	165	230	8
65	PN 16	PN 10	185	280	10
80	PN 16	PN 10	200	300	14
100	PN 16	PN 10	220	315	21
125	PN 16	PN 10	250	400	26
150	PN 16	PN 6	285	505	44
200	PN 10	PN 6	340	530	72
250	PN 10	PN 6	395	620	100
300	PN 10	PN 6	445	700	160
350	PN 10	PN 4	505	800	190
400	PN 10	PN 4	565	860	210
500	PN 10	PN 4	670	945	275

All measurements in mm. Flanges according to EN 1092-2/B. Weights are approximations.

Revision 1